

# DOREX 8500B/FC/FH/FS EXIT DEVICE TRIM

Compatible with 8500 and 8000 Series exit devices

## INSTALLATION INSTRUCTIONS

1. The hole positioning is determined by the exit device's position on the door's inside surface. Transfer the exit device horizontal and vertical reference centerlines from the inside door surface to the outside door surface.
2. Bore 2 1/8" (54 mm) through hole. Bore from both sides of door, to prevent damaging door surface.
3. Drill Holes "A", 5/16" (8 mm) diameter x 1/2" (13 mm) deep, for the trim posts, on the door exterior surface only (for lever trim only).
4. Make cutouts "B" for the trim tabs, on the door exterior surface only.
5. Insert knob or lever assembly through 2-1/8" (54 mm) hole on outside door face.
6. Cut-off tailpiece, if required, ensuring a minimum 1/4" (6.5 mm) projection beyond inside door surface.
7. Place mounting plate on inside door surface in orientation as indicated and attach firmly the trim to the door using the two machine screws.
8. Exit device head chassis to be installed as per exit device installation instructions.
9. Verify the trim and the exit device smooth operation for the appropriate function

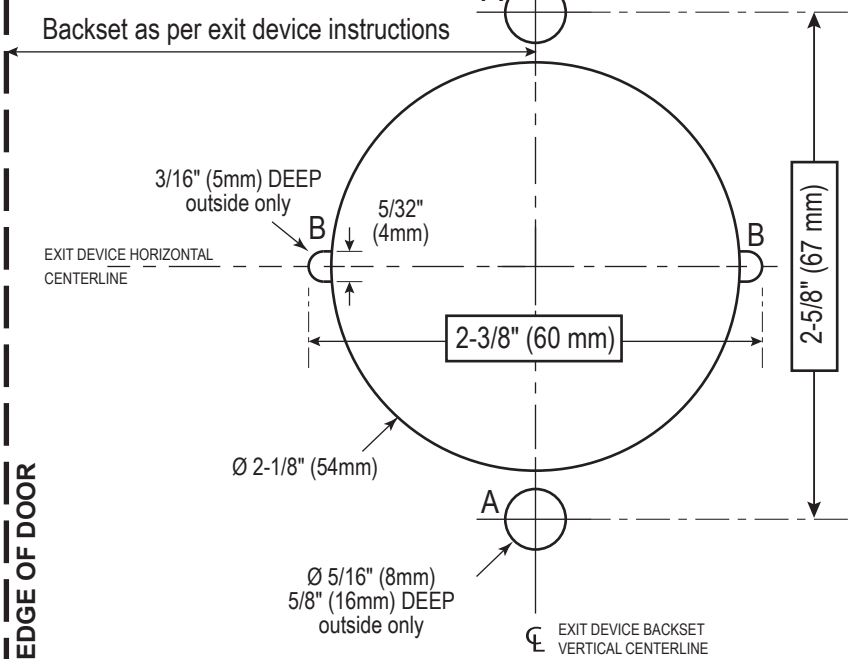

**!** Do not use template if not to scale. To verify, confirm boxed dimensions

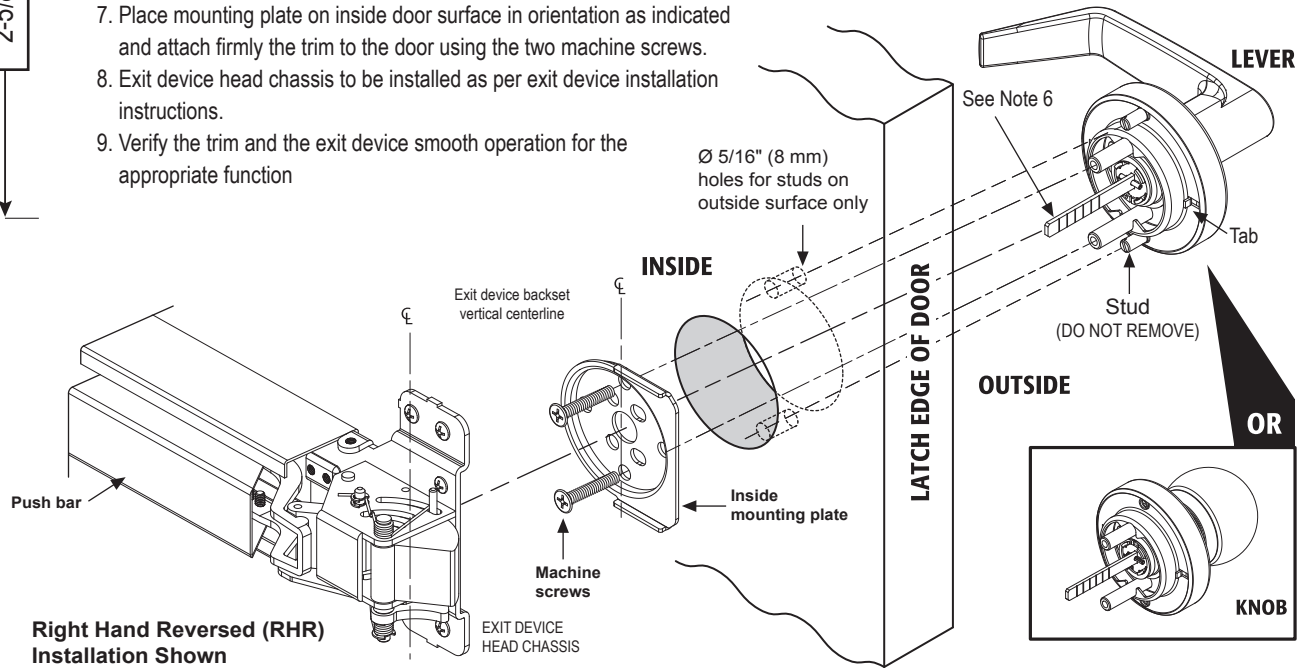

Right Hand Reversed (RHR) Installation Shown

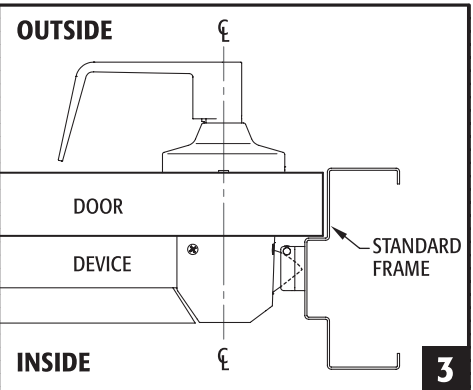
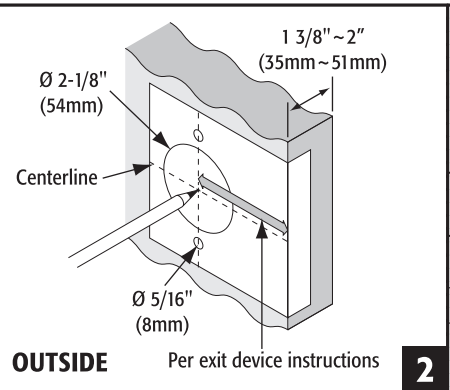
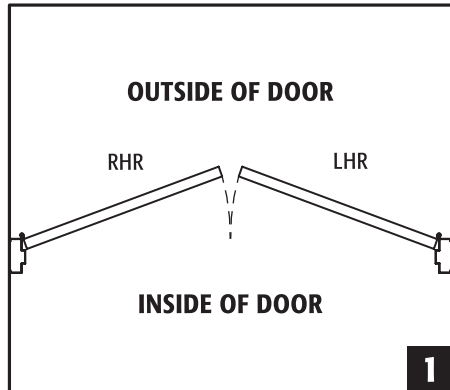

**!** When installing storeroom function (80) with clutch, the tailpiece must be in the horizontal position as shown.

