



DOREX® 1901

Installation Instructions

WITH 1901-CSA, 1901-CSANHO, 1901-SCSANHO
CUSHION STOP ARM (WITH / WITHOUT HOLD OPEN)

1 DOOR CLOSER INSTALLATION

Select required door opening angle, then mark the four (4) door closer mounting holes center locations using measurements from the table. Mark the five (5) hole locations on the inside frame (soffit) to mount the parallel bracket. Pre-drill 7/32" holes for wood screws or drill and tap for 1/4-20 for machine screws.

| Metal | Wood |
|---|---|
|  |  |
| #7 | 7/32" |
| 1/4-20 | |

 Incorrect installation or adjustment could cause damage or injury.
Read and follow instructions carefully.

Dimensions Inches (mm)

| DOOR OPENING | DIMENSION A |
|--------------|---------------|
| 85° | 3-15/16 (100) |
| 90° | 3-3/8 (86) |
| 100° | 2-1/2 (64) |
| 110° | 1-3/4 (44) |

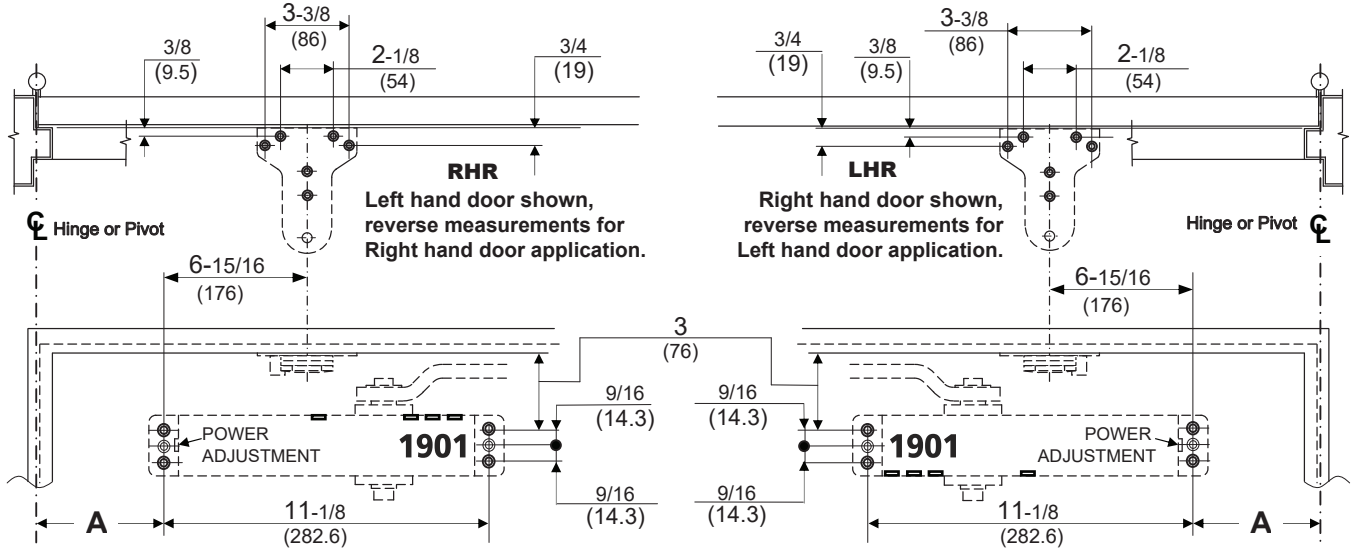

 For correct door closer operation, the door closer and parallel arm must be level through out the full door opening. If not, the misaligned part will be subject to bending, distortion and friction that will affect the door closer operation and useful life.

2 PARALLEL BRACKET CUSHION STOP CONFIGURATION

Configure the arm stop based on door closer installation (see Step 3) as indicated BEFORE installing bracket to the frame (see Step 4).

FOR RIGHT HAND REVERSED (RHR) INSTALLATION

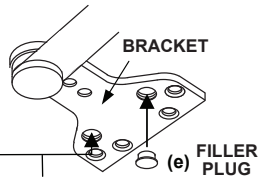

Insert SPRING STOP into hole as shown.

5/32" OR 4 mm Hex key

Insert ARM STOP into hole as shown.

FOR LEFT HAND REVERSED (LHR) INSTALLATION

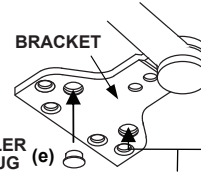

Insert ARM STOP into hole as shown.

Insert SPRING STOP into hole as shown.

5/32" OR 4 mm Hex key

3 DOOR CLOSER MOUNTING

 Speed adjusting valves must be positioned away from the hinges side of the door.

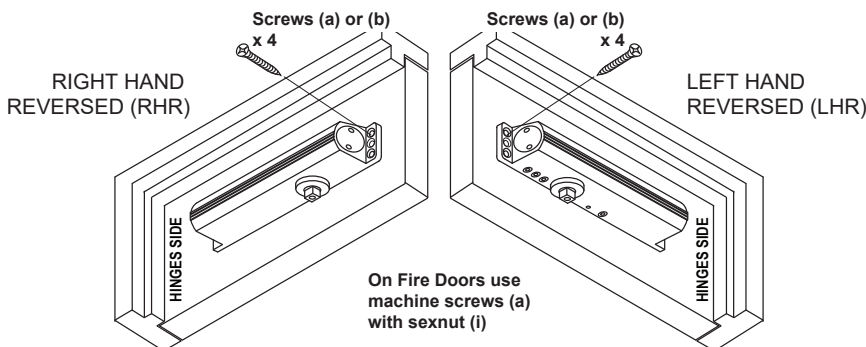

MOUNTING HARDWARE

Screw Pack (Cush Arm)

- (a) Machine x4
- (b) Wood x4
- (c) Machine x1
- (d) Wood x1
- (e) Filler Plug x1
- (f) x1
- (g) Spacer Block x1
- (h) x1

DOREX® 1901

Installation Instructions

WITH 1901-CSA, 1901-CSANHO, 1901-SCSANHO
CUSHION STOP ARM (WITH / WITHOUT HOLD OPEN)

4 PARALLEL BRACKET INSTALLATION

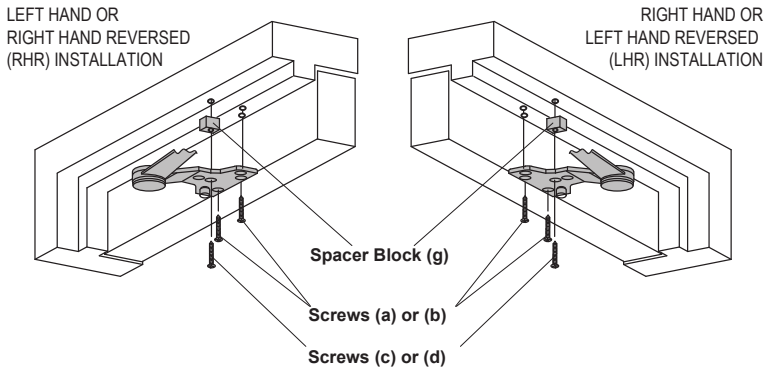

5 ARM MOUNTING AND PRELOAD

Use wrench at lower shaft, rotate shaft 45° towards the hinge side of the door as shown below, then install arm on top shaft and secure with screw (f).

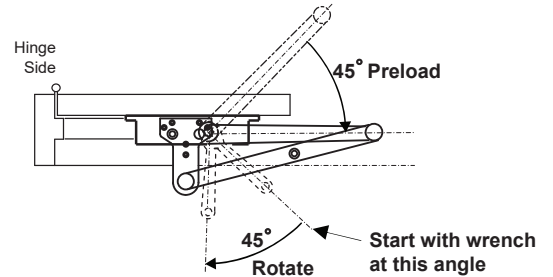

6 DOOR CLOSER ADJUSTMENT

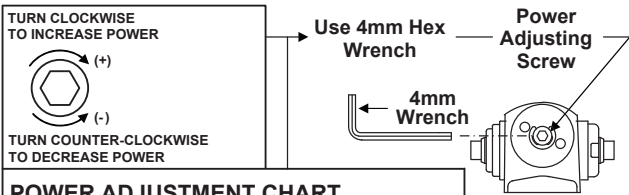

POWER ADJUSTMENT CHART

| DOOR CLOSER SIZE / POWER REQUIRED | No. OF FULL TURNS OF POWER ADJUSTING SCREW REQUIRED | MAXIMUM DOOR LEAF SIZE | | MAXIMUM DOOR WEIGHT |
|-----------------------------------|---|------------------------|----------------------|-------------------------------|
| | | INTERIOR | EXTERIOR (SWING OUT) | |
| 1 | - 8 | 5 lbs Opening | — | 33 - 65 LBS 15 - 30 KG |
| 2 | - 4 | 36" (0.91 m) | — | 60 - 90 LBS 27 - 41 KG |
| 3 | 0 (PRESET) | 42" (1.07 m) | 36" (0.91 m) | 85 - 140 LBS 38 - 63 KG |
| 4 | + 4 | 48" (1.22 m) | 42" (1.07 m) | 125 - 190 LBS 57 - 86 KG |
| 5 | + 8 | 54" (1.37 m) | 48" (1.22 m) | 175 - 265 LBS 80 - 120 KG |
| 6* | + 12 | 60" (1.52 m) | 54" (1.37 m) | 250 - 330 LBS 113 - 150 KG |

* Due to parallel installation, when adjusted to maximum power (Size 6), the actual door closing force will be reduced to the equivalent of Size 5.

CAUTION! Do not turn speed adjustment valves more than four (4) full turns counter clockwise from the fully closed position or an oil leak will result.

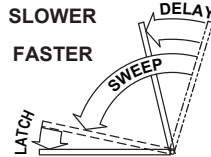
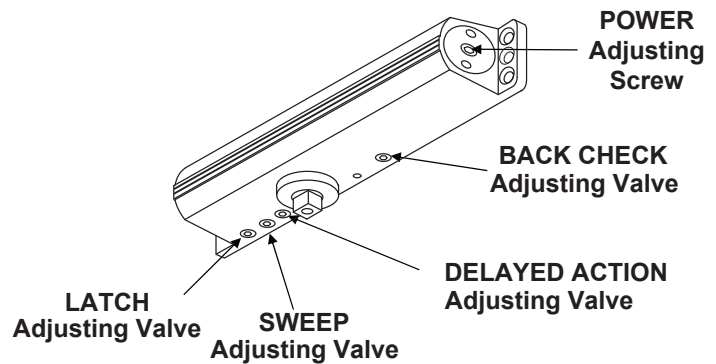

CLOSING CYCLE

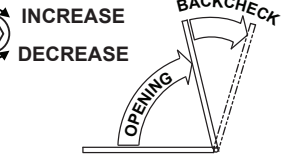

OPENING CYCLE

FOR SPEED CONTROL ADJUSTMENTS REFER TO THE CONTROL ADJUSTMENTS SUPPLIED WITH THE DOOR CLOSER

7 COVER INSTALLATION

Install cover and attach with supplied screws

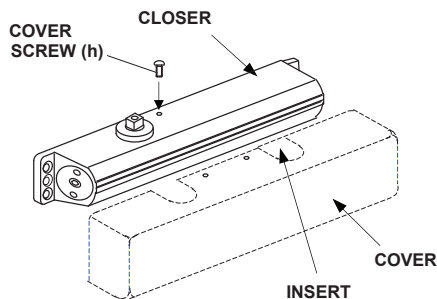

8 HOLD-OPEN (STOP) ENGAGEMENT

A quarter turn on the HOLD-OPEN CONTROL HANDLE engages or disengages hold-open. If handle does not engage properly, check and correct the parallel arm level.

